



Kinetic Systems

**ROBOTIQUE
COLLABORATIVE
MODULAIRE**



Vérins



Modules doubles



Modules simples



Tables



**Motorisation
et asservissement**

CONTACT

📍 Kinetic Systems
ZI Les Platères
150 rue Barthélémy Thimonnier
69440 Mormant, France
☎ +33 (0)4 78 48 74 28
✉ info@kinetic-systems.fr



Motion control

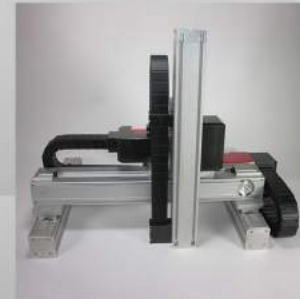

**Manipulateur 4 axes
modules doubles**

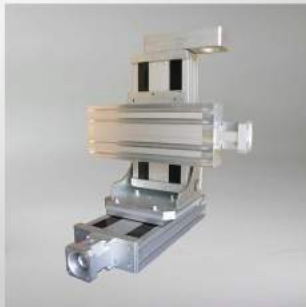

**Manipulateur 3 axes
modules doubles**



**Manipulateur 4 axes
modules simples**



La FRENCH TECH



La FRENCH FAB



ROBOT POLAIRE KS

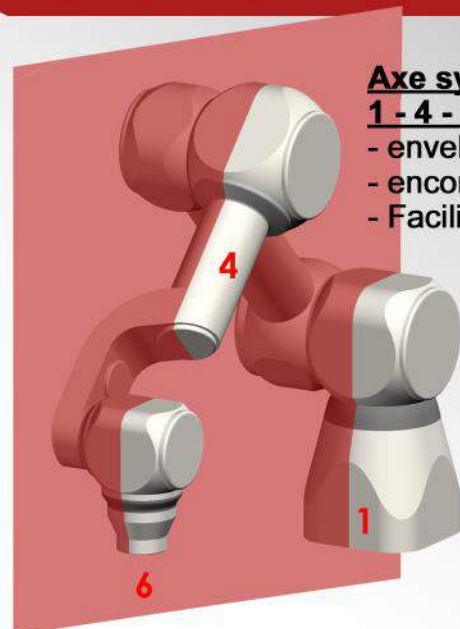

Axe symétrique 1 - 4 - 6 axés

- enveloppe de travail réduite
- encombrement réduit
- Facilité d'utilisation

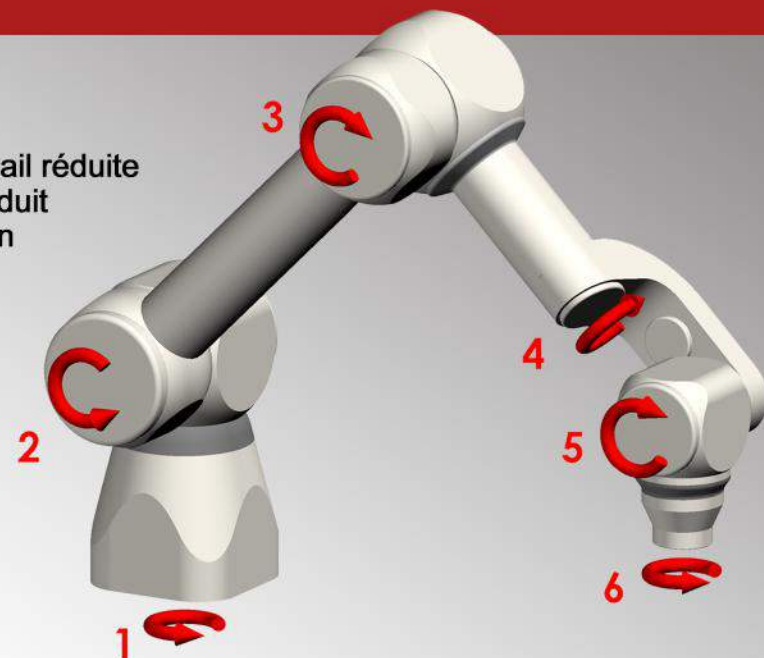

CARACTÉRISTIQUES

| Référence | KS4 | | KS8 | | KS16 | | KS16-32 |
|---|---------|---------|---------|----------|----------|-----------|-------------|
| | KS4-600 | KS4-900 | KS8-700 | KS8-1100 | KS16-900 | KS16-1600 | KS16-32-800 |
| Charge - Kg | 4 | 3 | 8 | 5 | 16 | 12 | 32 |
| Portée - mm (rayon entre 1 et 5) | 600 | 900 | 700 | 1100 | 900 | 1600 | 800 |
| Vitesse maxi - m/s circonférentielle | 2,5 | 2 | 2,4 | 1,8 | 2,2 | 1,6 | 1,2 |
| Répétabilité - mm | ±0,05 | | ±0,05 | | ±0,05 | | ±0,05 |
| Poids - Kg | 14,8 | 17,3 | 23,2 | 26,2 | 32 | 35,7 | 41 |

ENVELOPPE DE TRAVAIL

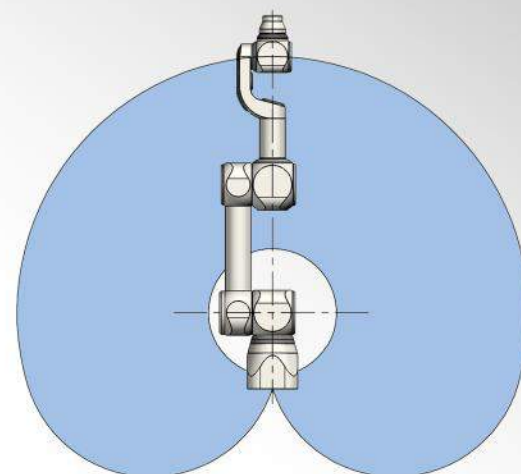
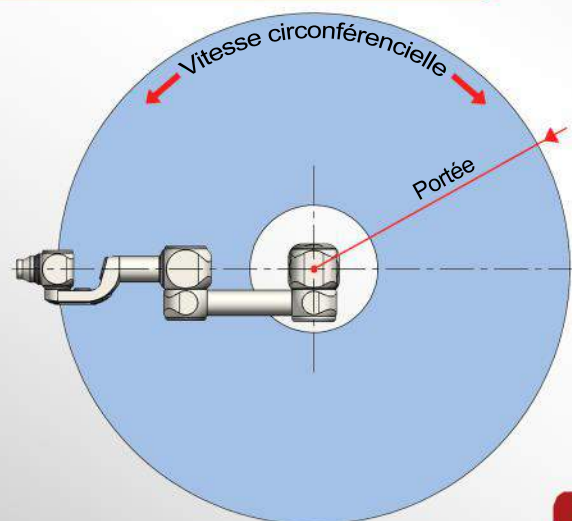

KS16-900

KS8-700

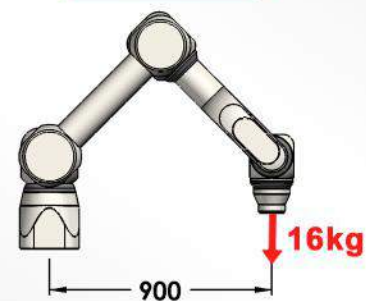
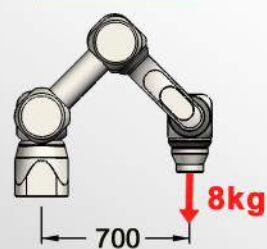

KS4-600

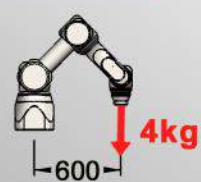

DE

MODULAIRE

A

ET PLUS

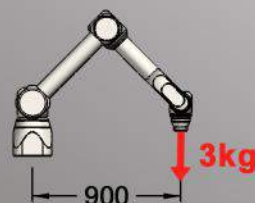

KS4-900

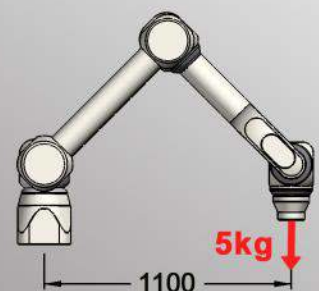

KS8-1100

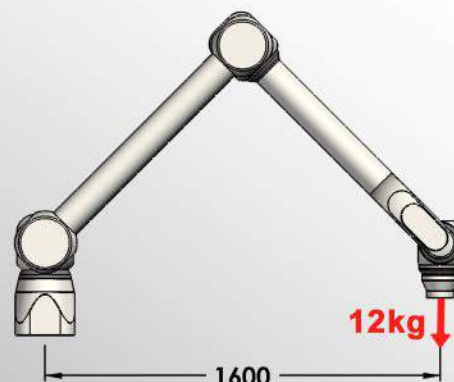

KS16-1600

EXECUTION APPLI

Charge >
Portée <
Vitesse <

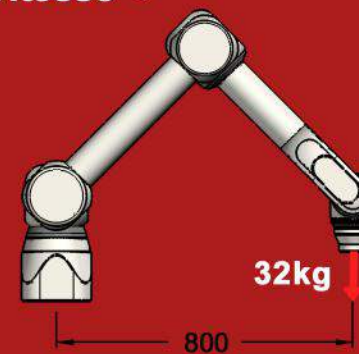

KS16-32-800

DONNÉES TECHNIQUES

| | |
|-------------------------------------|-------------------------|
| Codeur absolu | Sur tous les axes |
| Frein | Sur tous les axes |
| Classification IP | IP 65 |
| Classe ISO salle blanche | 5 |
| Salle blanche Classe de propreté | 2 |
| Plage de température | +5°C à +50°C |
| Supression | oui |
| Dépollution / nettoyage | Sans zones de rétention |
| Mode de fixation | Sol - mur - plafond |
| Alimentation | Câbles sous pieds |